

Ref: 40.029

Features:

- Protections: short circuit / over current / over voltage
- Cooling by free air convection
- Universal AC input / Full range
- Protection degree: IP67
- Protection class II
- Constant voltage design



Electrical characteristics	Power (W)	60W
	Voltage (V)	12V
	Output current range (A)	0~5A
Input specifications	Input voltage range	90-264Vac; 127 ÷ 370VDC
	Input frequency range	47Hz - 63Hz
	Efficiency	82%
	Input AC current	0.75A/115VAC, 0.35A / 230VAC
	Inrush current (typ.)	70A / 230VAC, 35A / 115VAC
	Leakage current max.	0.25mA / 240VAC
Output specifications	Output rated current	5A
	Output line regulation	±1%
	Output load regulation	±2%
	Output tolerance	±5%
	Ripple and noise	200mV
	Setup, rise time	1500ms, 800ms / 230VAC; 2500ms, 800ms / 230VAC at full load
	Hold up time	24ms / 115VAC, 50ms / 230VAC at full load
Protections	Over Current	Range: 150% - 200% rated current / Type: hiccup mode, auto-recovery.
	Short circuit	Type: hiccup mode, auto-recovery.
	Over voltage	13.5 ÷ 18.5V / Type: hiccup mode, auto-recovery.
Working environment	Working temperature	-30°C - 70°C (Refer to Derating Curve)
	Working humidity	20 - 90% RH non-condensing
	Storage temperature and humidity	-40°C - 80°C, 10 - 95% RH non-condensing
	Temperature coefficient	± 0.03% / °C (0°C - 50°C)
	Vibration	10 - 500Hz, 2G, 10min / cycle, period for 60min. each along X, Y, Z axes
Other	Dimension	162x42x33mm
	Weight	0.39Kg
	Guarantee	5 years



Assembly and safety information

Applied standards:

- EN 61347-1
- EN 61347-2-13
- EN 55024
- EN 61000-3-2
- EN 61000-3-3
- EN 61547
- EN 61000-4-2
- EN 61000-4-3
- EN 61000-4-4
- EN 61000-4-5
- EN 61000-4-6
- EN 61000-4-8
- EN 61000-4-11
- EN 55015

Measurements:

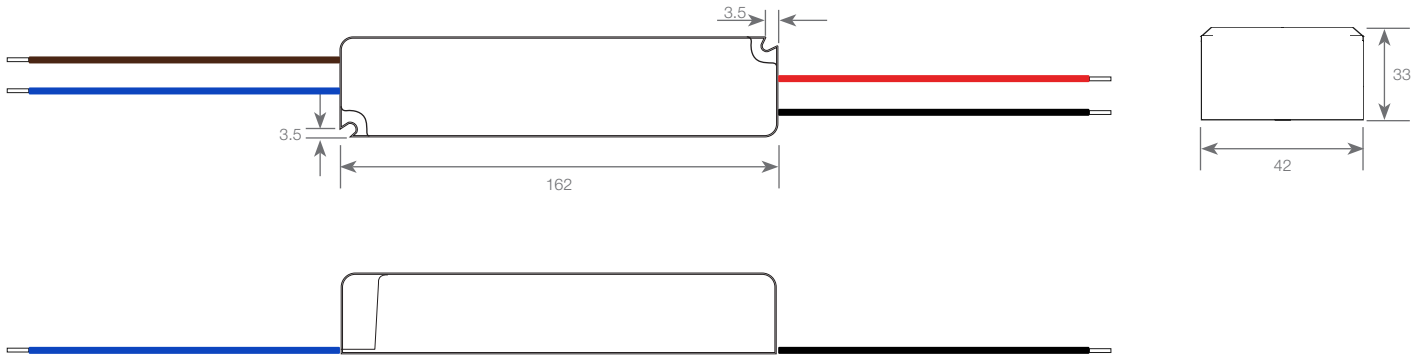
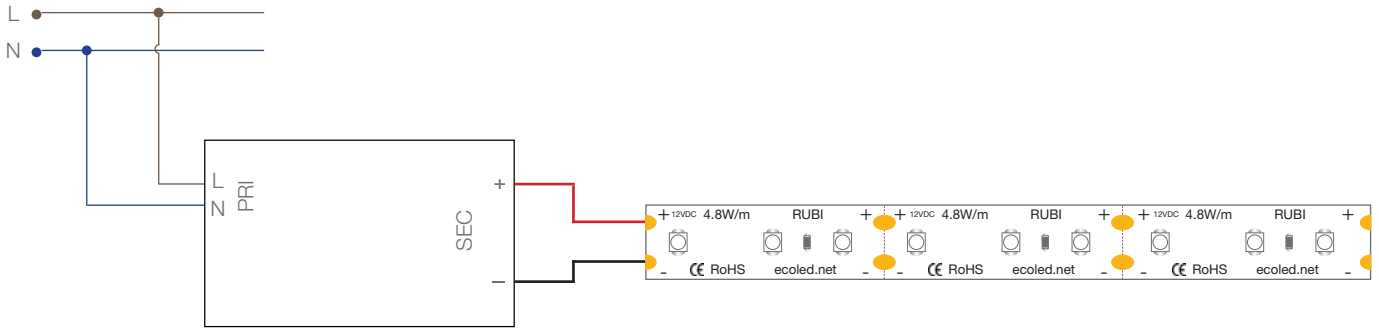
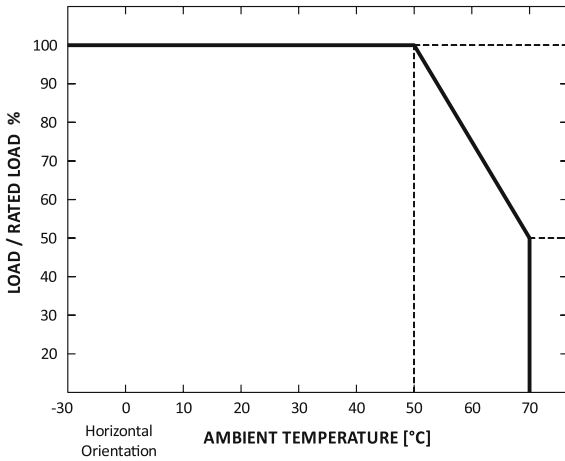

Diagram:



Graphics:

Derating curve



Static characteristic

